

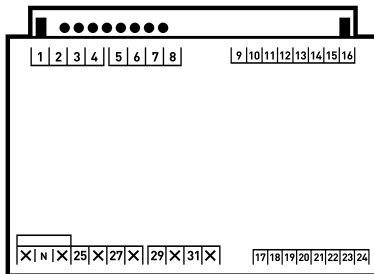

1x

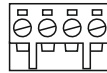

4x



1x



2x

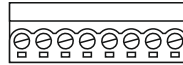

4x



1 DEVICE DESCRIPTION

1.1 Key features

- a** OPTI-ENER was designed and manufactured to optimize consumption of electric power. Device helps user to manage energy surpluses that was produced by electric generator e.g. photovoltaic installation, wind turbines etc. Customer has full control of AC/DC parameters.
- b** Controller is adjusted to be installed in electrical switchgear directly to DIN/TH 35 rails.
- c** Due to measurements OPTI-ENER does accounts of electric power that is produced for example by PV installation, used by household and transferred to energy company or accumulators.
- d** Thanks to EKOLAN module user has remote access to various energy meters, real-time parameters and control of electrical devices.
- e** All data is captured and saved in cloud solution at external servers.
- f** User is able to control electrical circuit or specific devices manually or automatically. Management of energy surplus is realized by website: <https://opti-ener.com/>.

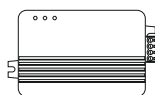

Modem
EKO-LAN
6927



OPTI-ENER
MADE BY HEWALEX

g OPTI-ENER capabilities:

- Voltage, current and power measure at 4 channels,
- Balance of phases energy consumption,
- Power supply administration of 4 electrical circuits or specific devices,
- Ability to control electrical circuits and devices according to energy surplus,
- Ability to control electrical circuits and devices automatically by time schedule,
- Ability to control electrical circuits and devices automatically by mobile application.

1.2 Input and output:

Controller has various inputs that provide voltage and current measure. OPTI-ENER also has been equipped with a communication port - RS 485. Specific placement of electric contacts was pictured at figure number 1. Additionally at the cover of a device there are configuration buttons and signal diodes, which were described in point 1.3.

Fig. 1. OPTI-ENER – front view

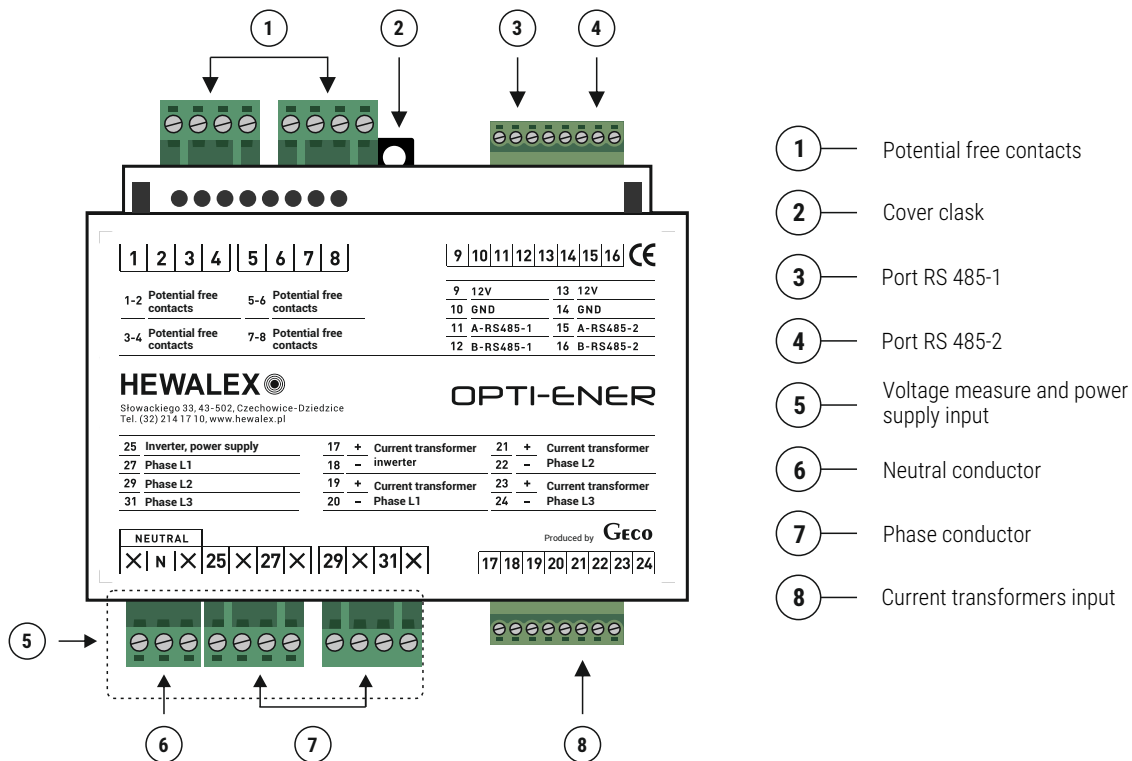
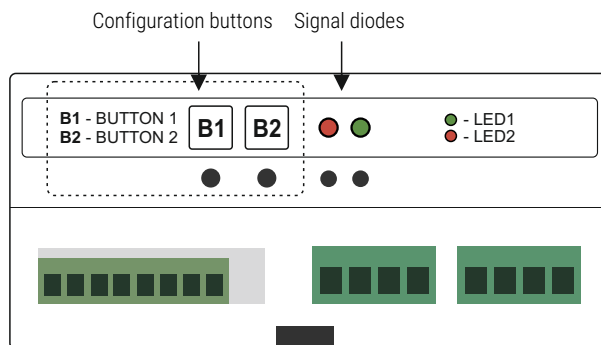

Fig. 2. OPTI-ENER overhead view



1.3 Configuration buttons

OPTI-ENER has been equipped with two buttons B1; B2 that are located at the top of cover. During proper work red diode (LED 2) is pulsing in series of 3. For users that owns optional modules OPTI-TEMP and Converter PV the green diode (LED 1) will turn on and pulse. Description and signalization of features initialized by B1; B2 buttons can be found in table 1.

Tab 1. Button description.

BUTTON	TIME [s]	DESCRIPTION	SIGNALIZATION
B1	4	Enter to the programming mode required in manual software update.	Green diode (LED 1) turns on and continue to pulse. Red diode (LED 2) is pulsing in series of 3
B2	1	Add optional module OPTI-TEMP; Converter PV to subnetwork	Green diode (LED 1) turns on/off for 1 second and continue to pulse. Red diode (LED 2) is pulsing in series of 3
B2	5	Reset of OPTI-ENER controller. Removes all optional devices from subnetwork	Green (LED 1) and red (LED 2) diodes turn on simultaneously for 1 second and turns off
B1+B2	5	Restore fabric settings	After 5 seconds of pressing B1+B2 the red diode (LED 2) will turn on and light continuously. Green diode (LED 1) will turn on for 1 second after releasing the buttons

1.4 Measure elements installation

Integral part of OPTI-ENER system are current transformers that allow to measure current in electrical circuits. They are mounted at outlets number 17-24. All phase conductors including one from inverter should be dragged through current transformer.

Correct installation of current transformers was pictured at figure number 3. Current wires from AZ and ACX series are closely related with output numbers. Connection should be compatible with electrical scheme.

Phase conductors should be plugged in outlets number 25-31. As a result OPTI-ENER will measure voltage which is necessary to evaluate power value for each electrical circuit.

Output details are gathered in table number 2.

Fig. 3. Proper location of current transformers

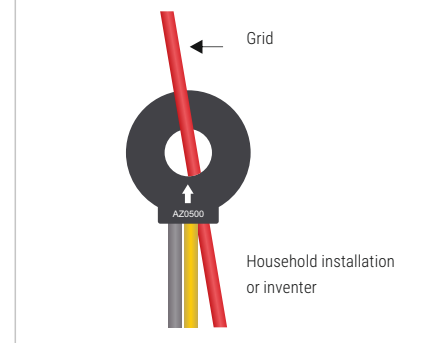

Tab 2. Outputs number description.

Measure circuit number	Output number		Phase
	Voltage measure	Current measure	
1	25	17, 18	L1i
2	27	19, 20	L1
3	29	21, 22	L2
4	31	23, 24	L3

CAUTION: Direction of current flowing is crucial to measured values. Make sure that current transformer has been installed properly.

ATTENTION!

Period when PV installation wasn't covered by monitoring system is not taken into the account of measured parameters. Maximum tolerance of measurement is up to +/- 2,5%.

1.5 Electrical consumers connection

OPTI-ENER has been equipped with 4 potential-free contacts with following parameters:

- Nominal voltage: 230 V AC
- Nominal Current: 8 A

If overcurrent protection device mounted at separate electrical circuit has bigger permissible current range than addition contactors should be installed. Current range of contactors must be at least equal (or bigger) to overcurrent protection device.

Fig. 4. Electrical scheme

Legend:

- L1,L2,L3,N – three-phase power supply 3x230V/400V, 50 Hz
- L1i,L2i,L3i,Ni – inverter output three-phase 3x230V/400V, 50 Hz
- S1 – three-phase overcurrent protection device
- S2 – overcurrent protection device
- S3 – overcurrent protection device
- S4 – overcurrent protection device
- RG – switch-disconnector
- RCD – residual current device breaker

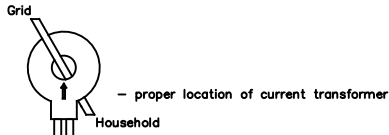
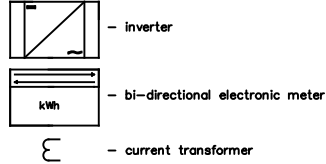

„-“ – black wire
„+“ – yellow wire

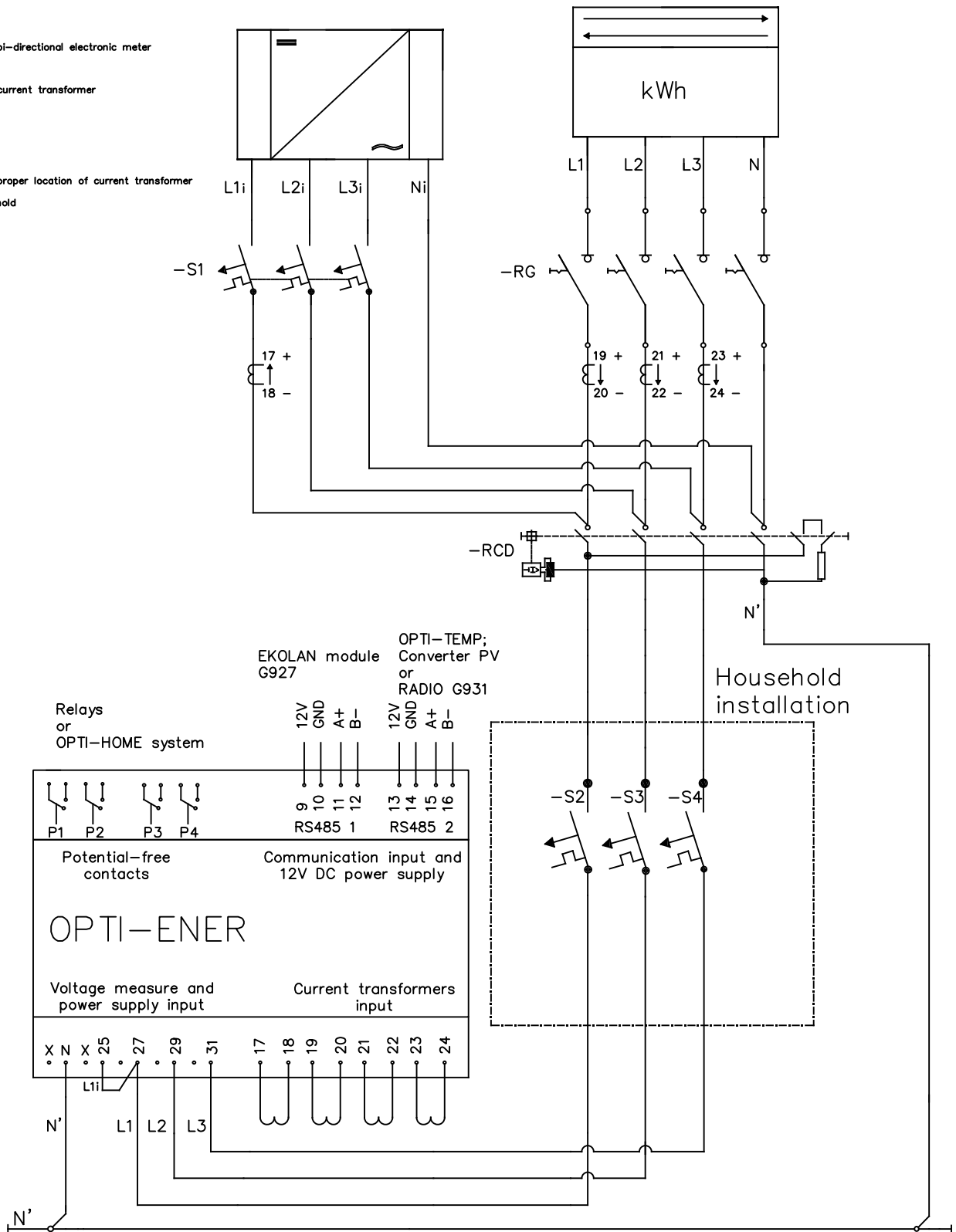

Fig. 5. OPTI-ENER and optional modules connection scheme

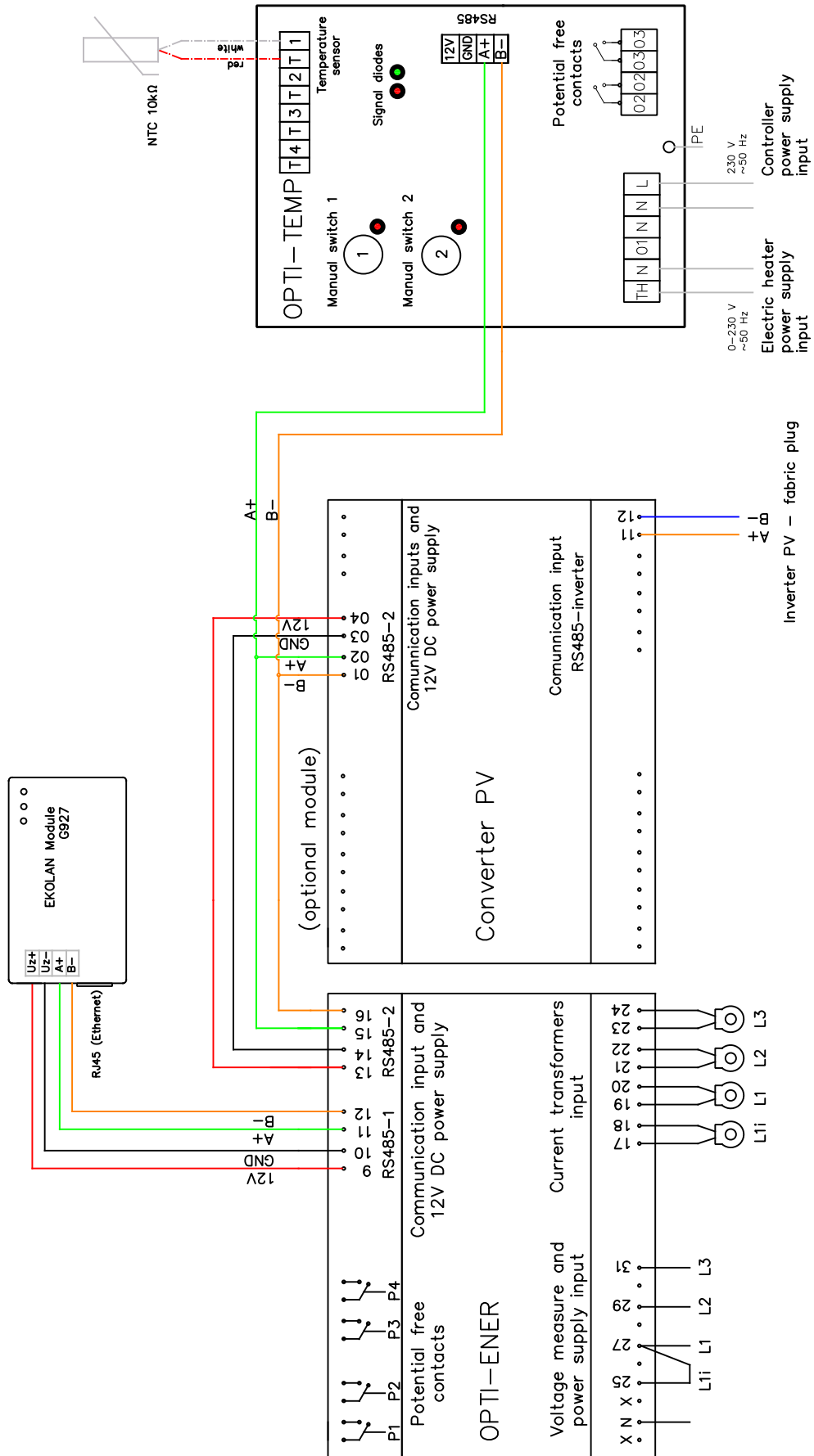

Fig. 6. OPTI-ENER and optional modules connection scheme by the RADIO G931

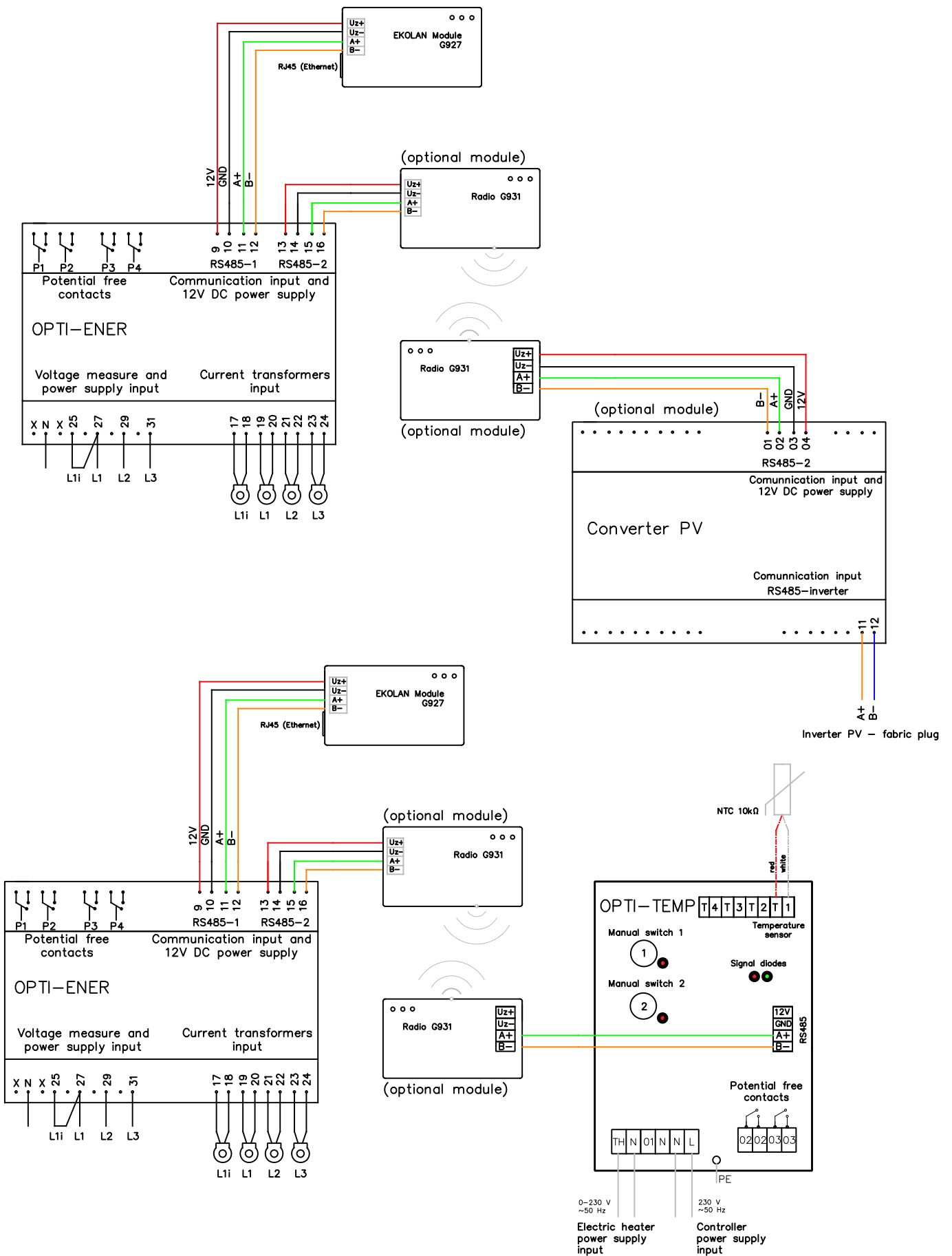
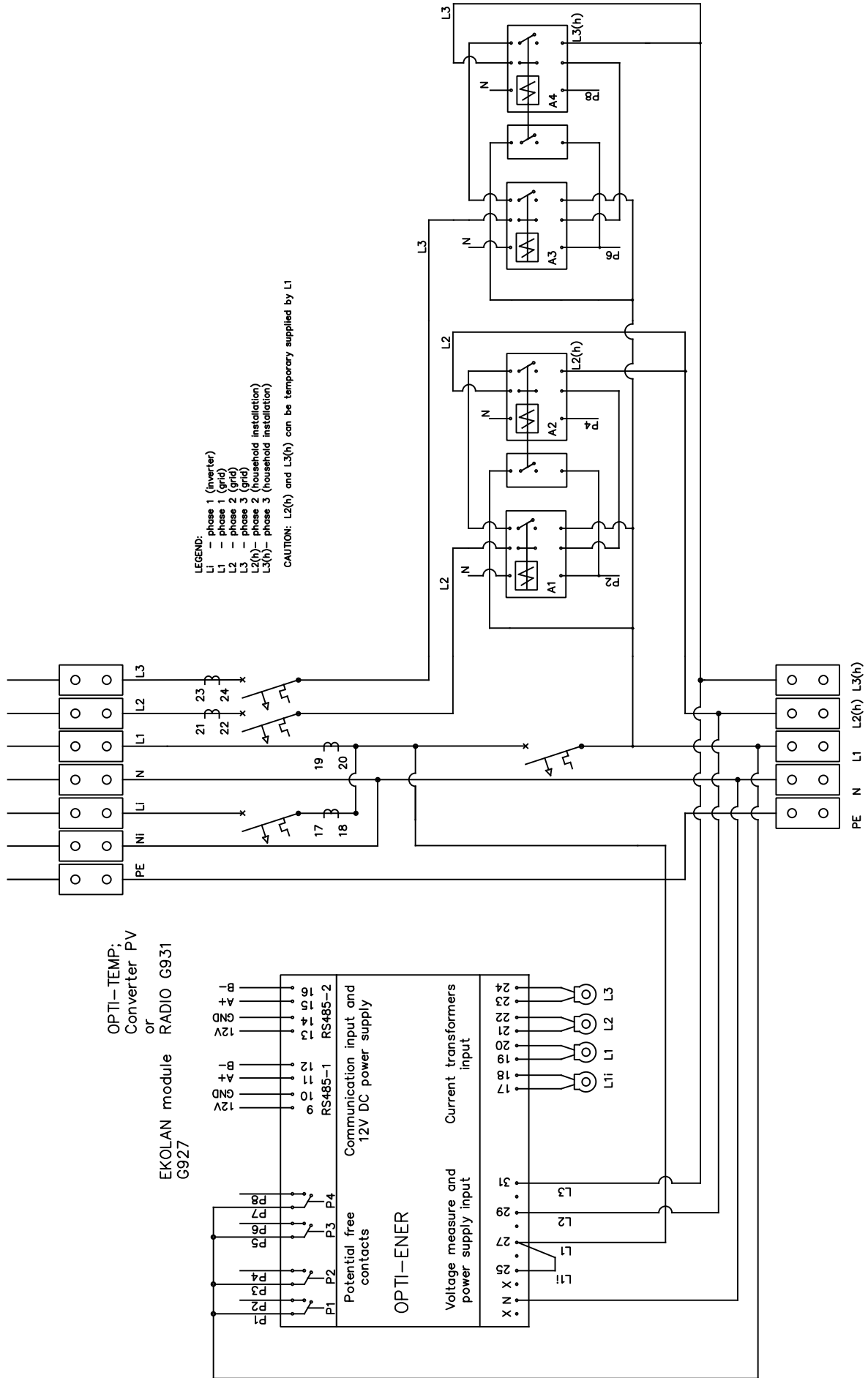

Fig. 7. OPTI-ENER connection scheme – circuit control



3 Information on marking and collecting used electrical and electronic equipment.



A symbol found on the product or its packaging points to the necessity of separate collection of used electronic equipment. This means that the product must not be thrown away together with other household waste. Correct disposal of old and used electrical equipment may help to avoid potential damage to the environment and human health.

A user who should give the used equipment to a collector should be responsible for separate collection of used electronic equipment.

CAUTION!

Device is not destined to be used by children and people with limited physical abilities, physical feeling or psychical disorders. It should not also be used by people who do not have proper experience or knowledge unless they were instructed or supervised by qualified personnel.

To download current technical documentation please scan following code:

